

Based on clinical observations and should not be considered medical advice. Individual results for timeline and repair tissue progress will vary.

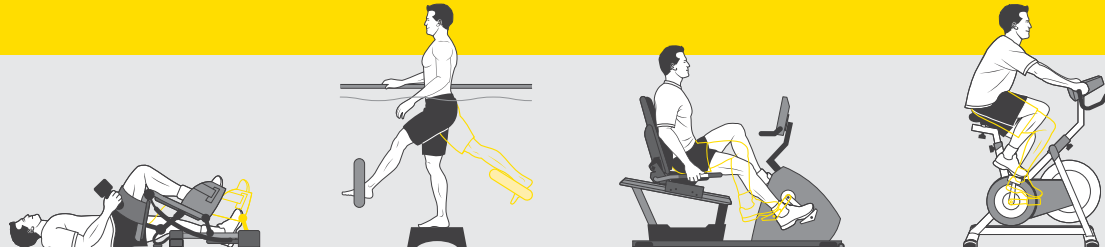

autologous cultured
chondrocytes
on porcine
collagen membrane

TIBIOFEMORAL JOINT INITIAL REHABILITATION PLAN





To design a rehabilitation program following a MACI procedure, it is important to take into account individual patient factors (such as age, weight, general health, and concomitant procedures) along with the physical biomechanics of the knee.

Particular attention should be paid to whether the repair site is in the patellofemoral or tibiofemoral joint. This ensures rehabilitation exercises do not inflict deleterious forces on the repair site. The primary goal of the rehabilitation program is to protect the graft while promoting maturation of the newly implanted chondrocytes through a program that focuses on three main components:

1. Regaining full range of motion (ROM)
2. Progressive weight bearing (WB)
3. Lower extremity strengthening, flexibility, and proprioceptive training¹

Follow these guidelines to help develop a patient-specific rehabilitation program for a patient receiving MACI treatment in the tibiofemoral joint.

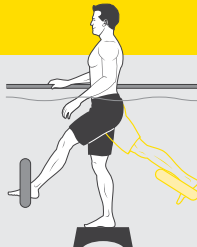
Note: Primary emphasis should be placed on reaching goals rather than following a strict timeline.

	 IMMEDIATE POST-OP 0-1 week following surgery	 RESTORE MOBILITY 2-3 weeks following surgery	 STRENGTHEN & STRAIGHTEN 4-6 weeks following surgery	 INDEPENDENT MOVEMENT 7-12 weeks following surgery
Goals	Maintain joint mobility and muscle tone while adhering to all precautions	Proficient heel-to-toe gait using 2 crutches and brace at 30% WB Pain-free knee flexion of 90° and full passive knee extension Ability to generate an active, isometric quadriceps contraction	Pain-free active knee flexion to 125° Ability to perform straight-leg raise in home exercises Pain-free gait using 1-2 crutches, brace, and 60% WB	Pain-free active knee ROM within anatomical limits Pain-free 6-minute walk test ^{2,3} , no ambulatory aids Progress to full WB
Weight bearing (WB) % of body weight	<20%	Progress from <20%–30%	Progress from <40%–60%	Progress from 80%–full (Weeks 8-10)
Range of motion (ROM)	Passive and active, progress from 0°–30°	Active, progress from 30°–90°	Active, progress from 110°–125°	Active, full (Weeks 7-8)
Protective knee bracing	Progress from 0°–30°	Progress from 30°–45°	Progress from 45°–full extension	Allow full knee flexion within brace
Ambulatory aids	2 crutches	2 crutches	1-2 crutches	Full WB indoors, 1 crutch outdoors and in unfamiliar areas

Refer to full MACI Rehabilitation Manual for continuation of rehabilitation plan beyond these initial 4 phases.



autologous cultured
chondrocytes
on porcine
collagen membrane



64 Sidney Street
Cambridge, MA 02139
800-453-6948
WWW.MACI.COM

INDICATION

MACI® (autologous cultured chondrocytes on porcine collagen membrane) is an autologous cellularized scaffold product that is indicated for the repair of single or multiple symptomatic, full-thickness cartilage defects of the adult knee, with or without bone involvement.

MACI is intended for autologous use and must only be administered to the patient for whom it was manufactured. The implantation of MACI is to be performed via an arthrotomy to the knee joint under sterile conditions.

The amount of MACI administered is dependent upon the size (surface in cm²) of the cartilage defect. The implantation membrane is trimmed by the treating surgeon to the size and shape of the defect, to ensure the damaged area is completely covered, and implanted cell-side down.

Limitations of Use

Effectiveness of MACI in joints other than the knee has not been established.

Safety and effectiveness of MACI in patients over the age of 55 years have not been established.

IMPORTANT SAFETY INFORMATION

MACI is contraindicated in patients with a known history of hypersensitivity to gentamicin, other aminoglycosides, or products of porcine or bovine origin. MACI is also contraindicated for patients with severe osteoarthritis of the knee, inflammatory arthritis, inflammatory joint disease, or uncorrected congenital blood coagulation disorders. MACI is also not indicated for use in patients who have undergone prior knee surgery in the past 6 months, excluding surgery to procure a biopsy or a concomitant procedure to prepare the knee for a MACI implant.

MACI is contraindicated in patients who are unable to follow a physician-prescribed post-surgical rehabilitation program.

REFERENCES

1. Gillogly SD, Voight M, Blackburn T. Treatment of articular cartilage defects of the knee with autologous chondrocyte implantation. *J Orthop Sports Phys Ther.* 1998;28(4):241-51.
2. Eberl JR, Robertson WB, Lloyd DG, Zheng MH, Wood DJ, Ackland T. Traditional vs accelerated approaches to post-operative rehabilitation following matrix-induced autologous chondrocyte implantation (MACI): comparison of clinical, biomechanical and radiographic outcomes. *Osteoarthritis Cartilage.* 2008;16:1131-40.
3. Enright PL. The six-minute walk test. *Respir Care.* 2003;48(8):783-5.

The safety of MACI in patients with malignancy in the area of cartilage biopsy or implant is unknown. Expansion of present malignant or dysplastic cells during the culturing process or implantation is possible.

Patients undergoing procedures associated with MACI are not routinely tested for transmissible infectious diseases. A cartilage biopsy and MACI implant may carry the risk of transmitting infectious diseases to healthcare providers handling the tissue. Universal precautions should be employed when handling the biopsy samples and the MACI product.

Final sterility test results are not available at the time of shipping. In the case of positive sterility results, health care provider(s) will be contacted.

To create a favorable environment for healing, concomitant pathologies that include meniscal pathology, cruciate ligament instability and joint misalignment, must be addressed prior to or concurrent with the implantation of MACI.

Local treatment guidelines regarding the use of thromboprophylaxis and antibiotic prophylaxis around orthopaedic surgery should be followed. Use in patients with local inflammations or active infections in the bone, joint, and surrounding soft tissue should be temporarily deferred until documented recovery.

The MACI implant is not recommended during pregnancy. For implantations post-pregnancy, the safety of breast feeding to infant has not been determined.

Use of MACI in pediatric patients (younger than 18 years of age) or patients over 65 years of age has not been established.

The most frequently occurring adverse reactions reported for MACI (≥5%) were arthralgia, tendonitis, back pain, joint swelling, and joint effusion.

Serious adverse reactions reported for MACI were arthralgia, cartilage injury, meniscus injury, treatment failure, and osteoarthritis.

MACI® and MyCartilage Care® are registered trademarks of Vericel Corporation. ©2018 Vericel Corporation. All rights reserved. PP.US.MAC.0482

HIGHLIGHTS OF PRESCRIBING INFORMATION

These highlights do not include all the information needed to use MACI safely and effectively. See full prescribing information for MACI.

MACI® (autologous cultured chondrocytes on porcine collagen membrane)

Cellular sheet for autologous implantation

Initial U.S. Approval: 2016

RECENT MAJOR CHANGES

Dosage and Administration, shaping the MACI implant (2.2) 06/2017

INDICATIONS AND USAGE

MACI® is an autologous cellularized scaffold product indicated for the repair of symptomatic, single or multiple full-thickness cartilage defects of the knee with or without bone involvement in adults. (1)

Limitations of Use

- Effectiveness of MACI in joints other than the knee has not been established.
- Safety and effectiveness of MACI in patients over the age of 55 years have not been established.

DOSAGE AND ADMINISTRATION

For autologous implantation only.

- Contact Vericel at 1-800-453-6948 or www.MACI.com regarding training materials for surgical implantation of MACI. (2)
- The amount of MACI implanted depends on the size (surface area in cm²) of the cartilage defect. (2.1)
- MACI should be trimmed to the size and shape of the defect and implanted with the cell-side down. (2.2)

DOSAGE FORMS AND STRENGTHS

Each 3 x 5 cm cellular sheet (MACI implant) consists of autologous cultured chondrocytes on a resorbable porcine Type I/III collagen membrane, at a density of at least 500,000 cells per cm². (3)

CONTRAINDICATIONS

- Known history of hypersensitivity to gentamicin, other aminoglycosides, or products of porcine or bovine origin. (4)
- Severe osteoarthritis of the knee. (4)

- Inflammatory arthritis, inflammatory joint disease, or uncorrected congenital blood coagulation disorders. (4)
- Prior knee surgery (within 6 months), excluding surgery to procure a biopsy or a concomitant procedure to prepare the knee for a MACI implant. (4)
- Inability to cooperate with a physician-prescribed post-surgical rehabilitation program. (4)

WARNINGS AND PRECAUTIONS

- Safety of MACI in patients with malignancy in the area of cartilage biopsy or implant is unknown. Expansion of malignant or dysplastic cells present in biopsy tissue during manufacture and subsequent implantation may be possible. (5.1)
- Because patients undergoing procedures associated with MACI are not routinely tested for transmissible infectious diseases, cartilage biopsy and MACI implant may carry risk of transmitting infectious diseases. (5.2)
- Local inflammation or active infection in the bone, joint, and surrounding soft tissue, meniscal pathology, cruciate ligament instability, and misalignment should be assessed and treated prior to or concurrent with MACI implantation. (5.3)
- Final sterility test results are not available at the time of shipping. (5.4)

ADVERSE REACTIONS

The most frequently occurring adverse reactions (≥5%) reported for MACI were arthralgia, tendonitis, back pain, joint swelling, and joint effusion. (6)

Serious adverse reactions reported for MACI were arthralgia, cartilage injury, meniscus injury, treatment failure, and osteoarthritis. (6)

To report SUSPECTED ADVERSE REACTIONS, contact Vericel at 1-800-453-6948 or FDA at 1-800-FDA-1088 or www.fda.gov/medwatch for voluntary reporting of adverse reactions.

USE IN SPECIFIC POPULATIONS

Pregnancy: Because MACI implantation requires invasive surgical procedures, use in pregnancy is not recommended. (8.1)

See 17 for PATIENT COUNSELING INFORMATION

Revised: 06/2017

FULL PRESCRIBING INFORMATION: CONTENTS*

1	INDICATIONS AND USAGE	8.2	Lactation
2	DOSAGE AND ADMINISTRATION	8.4	Pediatric Use
2.1	Dosage	8.5	Geriatric Use
2.2	Preparation and Implantation Procedure	11	DESCRIPTION
2.3	Postsurgical Rehabilitation	12	CLINICAL PHARMACOLOGY
3	DOSAGE FORMS AND STRENGTHS	12.1	Mechanism of Action
4	CONTRAINDICATIONS	12.3	Pharmacokinetics
5	WARNINGS AND PRECAUTIONS	13	NONCLINICAL TOXICOLOGY
5.1	Malignancy	13.1	Carcinogenesis, Mutagenesis, Impairment of Fertility
5.2	Transmissible Infectious Diseases	13.2	Animal Toxicology and/or Pharmacology
5.3	Presurgical Assessment of Comorbidities	14	CLINICAL STUDIES
5.4	Product Sterility	15	REFERENCES
6	ADVERSE REACTIONS	16	HOW SUPPLIED/STORAGE AND HANDLING
6.1	Clinical Trials Experience	17	PATIENT COUNSELING INFORMATION
6.2	Postmarketing Experience		
8	USE IN SPECIFIC POPULATIONS		
8.1	Pregnancy		

*Sections or subsections omitted from the full prescribing information are not listed.

FULL PRESCRIBING INFORMATION

1 INDICATIONS AND USAGE

MACI[®] (autologous cultured chondrocytes on porcine collagen membrane) is an autologous cellularized scaffold product indicated for the repair of single or multiple symptomatic, full-thickness cartilage defects of the knee with or without bone involvement in adults.

Limitations of Use

- Effectiveness of MACI in joints other than the knee has not been established.
- Safety and effectiveness of MACI in patients over the age of 55 years have not been established.

2 DOSAGE AND ADMINISTRATION

For Autologous Implantation Only.

Contact Vericel at 1-800-453-6948 or www.MACI.com regarding training materials for surgical implantation of MACI.

2.1 Dosage

- The amount of MACI implanted depends on the size (surface area in cm²) of the cartilage defect. The surgeon should trim the MACI implant to the size and shape of the defect, to ensure the damaged area is completely covered.
- MACI implant is for single-use. Multiple implants may be used if there is more than one defect. The size of MACI is adjusted for the size of each cartilage defect.

2.2 Preparation and Implantation Procedure

Preparation

- Confirm that the patient's identity matches the patient's identifiers on the MACI labels.
- Inspect the sealed MACI packaging for leaks and for any evidence of damage or contamination.
- DO NOT USE if the patient identifiers do not match, or there are signs of damage to the packaging. Contact MACI representative immediately or call Vericel Customer Care at 1-800-453-6948.
- Keep MACI at room temperature in its original packaging (outer shipping box). Do not unpack the MACI shipping box until the surgical site has been prepared.

Implantation Procedure

- Perform implantation procedure during arthrotomy using sterile surgical techniques.

- Follow the implantation with an appropriate, physician-prescribed rehabilitation program [see *Dosage and Administration (2.3)*].

Preparing Defect

- For chondral defects, remove all damaged and fibrous tissue on the defect bed. Debride the defect bed back to stable cartilage with vertical walls down to the subchondral bone by removing as little healthy cartilage as possible (Figure 1). Do not penetrate the subchondral bone.

Figure 1: Preparing Defect Bed

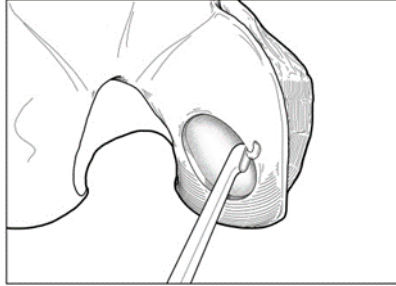

- For osteochondral defects, debride the defect bed back to stable cartilage with vertical walls down to healthy stable bone.
- Avoid bleeding through the subchondral plate. If bleeding occurs, use a suitable hemostatic agent to control the bleeding.

Creating Defect Template

- Create an exact template of the defect (Figure 2).

Figure 2: Creating Defect Template

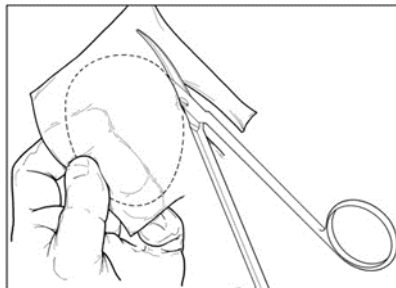

- Create orientation markers on the template to assist with proper orientation of the MACI implant. Turn the marked template over to ensure that the cells will be properly placed into the defect.

Preparing MACI Implant

- Unpacking MACI implant box (outside sterile field).
 - Unpack MACI implant shipping box.
 - Remove the outer bag containing a covered dish holding the MACI implant.

Note: Keep the dish upright at all times.

- Remove the self-seal pouch containing the dish from the outer bag (Figure 3).

Figure 3: Covered Dish in Self-Sealed Pouch

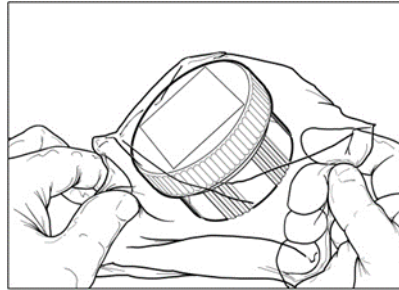

- Tear notches on the self-seal pouch to open the pouch and remove the covered dish.

Note: Do not remove the MACI implant from the dish until ready to be used.

- Unpacking the MACI implant dish (Figure 4)
 - When ready, a team member outside the sterile field but adjacent to the sterile prep table, will twist open and remove the lid from the dish.
 - Sterile field team member using sterile forceps will remove and discard the inner 5-pronged ring.
 - Sterile field team member will use 2 sterile non-tooth forceps to grasp the MACI implant corners and place the MACI implant onto the sterile work surface.

Figure 4: Unpacking MACI Implant

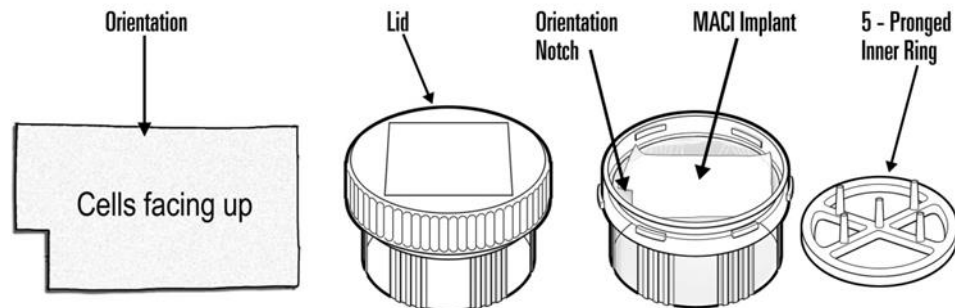

- The MACI implant has a rough side and a smooth side. The cells are seeded on the rough side and are facing up in the MACI dish. A notch in the lower left corner of the implant indicates that the cell-side is facing up. The cell-side of the MACI implant should remain facing up at all times until placement into the defect.

Note: The MACI implant must remain hydrated with the shipping media. Use the media from the dish to hydrate the implant if it ever starts to become dry after removal from the dish.

- Shaping the MACI implant
 - To maintain proper orientation, turn the template over and place it underneath the MACI implant, against the smooth, non-seeded side. The template should be visible through the translucent implant.

Note: Ensure minimal contact with the cell-seeded surface of the MACI implant.

- Using the template as a guide, cut the MACI implant to the correct size and shape.
- Place the custom-cut implant into a sterile intermediary dish, ensuring the cell-side up orientation and with adequate media from shipping dish to keep the implant hydrated.
- Place any remaining MACI implant into a separate intermediary dish with adequate media from the shipping dish to keep the implant hydrated. Discard if unused by the end of the implantation.

Placing MACI Implant

- Ensure defect area is dry and free of bleeding.
- Apply a thin layer of fibrin sealant to the entire base of the defect (bone) bed.
- Maintaining appropriate rotational orientation, place the custom-cut implant onto the defect bed cell-side down.
- Apply light digital pressure to the implant for approximately 3 minutes.
- Fibrin sealant may also be applied to the rim (periphery) of the implant. MACI implant fixation may also be supplemented with interrupted resorbable sutures if desired or if conditions warrant, particularly if the defect is uncontained (i.e, the cartilage defect is not 100% surrounded by a stable cartilage rim) or the lesion is larger than 10 cm².

2.3 Postsurgical Rehabilitation

A physician-prescribed rehabilitation program that includes early mobilization, joint range of motion, and weight bearing is recommended to promote graft maturation and reduce the risk of graft delamination, postoperative thromboembolic events, and joint stiffness. Stage this program to promote a progressive return to full joint range of motion and weight-bearing as well as muscle strengthening and conditioning. Return to recreational and sporting activity should be in consultation with healthcare professionals.

3 DOSAGE FORMS AND STRENGTHS

MACI implant is available as a cellular sheet, 3 x 5 cm, with a 0.5-cm² section removed from the lower left-hand corner, consisting of autologous cultured chondrocytes on a resorbable Type I/III collagen membrane at a density of at least 500,000 cells per cm².

4 CONTRAINDICATIONS

MACI is contraindicated in patients with the following conditions:

- Known history of hypersensitivity to gentamicin, other aminoglycosides, or products of porcine or bovine origin. [*see Description (11)*]
- Severe osteoarthritis of the knee (Kellgren-Lawrence grade 3 or 4).
- Inflammatory arthritis, inflammatory joint disease, or uncorrected congenital blood coagulation disorders.
- Prior knee surgery (6 months), excluding surgery to procure a biopsy or a concomitant procedure to prepare the knee for a MACI implant.
- Inability to cooperate with a physician-prescribed post-surgical rehabilitation program [*See Dosage and Administration (2.3)*].

5 WARNINGS AND PRECAUTIONS

5.1 Malignancy

The safety of MACI used in patients with malignancy in the area of cartilage biopsy or implant is unknown. The potential exists for expansion of malignant or dysplastic cells present in biopsy tissue during manufacture and subsequent implantation. In addition, implantation of normal autologous chondrocytes could theoretically stimulate growth of malignant cells in the area of the implant, although there have been no such incidents reported in humans or animals.

5.2 Transmissible Infectious Diseases

MACI is intended solely for autologous use. Patients undergoing the surgical procedures associated with MACI are not routinely tested for transmissible infectious diseases. Therefore, the cartilage biopsy and the MACI implant may carry the risk of transmitting infectious diseases to personnel handling these tissues. Accordingly, healthcare providers should employ universal precautions in handling the biopsy samples and the MACI product.

Product manufacture includes reagents derived from animal materials. All animal-derived reagents are tested for viruses, retroviruses, bacteria, fungi, yeast, and mycoplasma before use. Bovine materials are sourced to minimize the risk of transmitting a prion protein that causes bovine spongiform encephalopathy and may cause a rare fatal condition in humans called variant Creutzfeldt-Jakob disease.

These measures do not totally eliminate the risk of transmitting these or other transmissible infectious diseases and disease agents. Report the occurrence of a transmitted infection to Vericel Corporation at 1-888-453-6948.

5.3 Presurgical Assessment of Comorbidities

To create a favorable environment for healing, assess and treat the following conditions prior to or concurrent with implantation with MACI:

- Local inflammation or active infection in the bone, joint, and surrounding soft tissue: patients should be deferred until complete recovery.
- Meniscal pathology: presence of an unstable or torn meniscus requires partial resection, repair, or replacement prior to or concurrent with MACI implantation. MACI is not recommended in patients with a total meniscectomy.
- Cruciate ligament instability: the joint should not possess excessive laxity, which may create excessive shear and rotational forces across the joint. Both anterior and posterior cruciate ligaments should be stable or undergo reconstruction prior to or concurrent with MACI implantation.
- Misalignment: the tibio-femoral joint should be properly aligned, and patella tracking should be normalized. Varus or valgus misalignment of the tibio-femoral joint and abnormal patella tracking may abnormally load joint surfaces and jeopardize the implant. Misalignment and patella tracking should be addressed with a corrective osteotomy or similar corrective procedure prior to or concurrent with MACI implantation.

5.4 Product Sterility

MACI is shipped after passing preliminary test results from in-process microbial tests. A final sterility test is initiated prior to shipping, but the result will not be available prior to implantation. If microbial contamination is detected after the product has been shipped, Vericel will notify the healthcare provider(s) and recommend appropriate actions.

6 ADVERSE REACTIONS

The most frequently occurring adverse reactions ($\geq 5\%$) reported for MACI were arthralgia, tendonitis, back pain, joint swelling, and joint effusion.

Serious adverse reactions reported for MACI were arthralgia, cartilage injury, meniscus injury, treatment failure, and osteoarthritis.

6.1 Clinical Trials Experience

Because clinical trials are conducted under widely varying conditions, adverse reaction rates observed in the clinical trials of a product cannot be directly compared to rates in the clinical trials of another product and may not reflect the rates observed in practice.

In a 2-year prospective, multicenter, randomized, open-label, parallel-group clinical trial¹, 144 patients, ages 18 to 54 years, were randomized to receive a 1-time treatment with MACI or microfracture (1:1, 72 patients in each treatment group). Demographic characteristics of patients in the trial were similar in both treatment groups. The majority of patients were male (62.5% MACI, 66.7% microfracture), and the mean ages were 34.8 (MACI) and 32.9 (microfracture)

years. Overall, 70 patients in the MACI group and 67 patients in the microfracture group completed 2 years of follow-up.

In addition, all 144 subjects from the 2-year clinical trial had the option to enroll in a 3-year follow-up study (extension study). Safety and efficacy assessments were performed at yearly scheduled visits. The demographic characteristics of patients (N = 128) enrolled in the extension study were similar in both treatment groups and consistent with the overall population of the 2-year clinical trial.

The proportion of patients with at least 1 subsequent surgical procedure (any surgical procedure performed on the treated knee joint, including arthroscopy, arthrotomy, or manipulation under anesthesia) in the 2 years following study treatment was comparable between treatment groups (8.3% in the MACI group and 9.7% in the microfracture group).

Adverse reactions reported in $\geq 5\%$ of patients in either treatment group in the 2-year clinical trial are provided in Table 1.

Table 1. Adverse Reactions in $\geq 5\%$ of Patients in Any Treatment Group in the 2-Year Clinical Trial

System Organ Class	MACI n = 72 n (%)	Microfracture n = 72 n (%)
Musculoskeletal and Connective Tissue Disorders		
Arthralgia	37 (51.4)	46 (63.9)
Back pain	8 (11.1)	7 (9.7)
Joint swelling	7 (9.7)	4 (5.6)
Joint effusion	5 (6.9)	4 (5.6)
Injury, Poisoning and Procedural Complications		
Cartilage injury	3 (4.2)	9 (12.5)
Ligament sprain	3 (4.2)	5 (6.9)
Procedural pain	3 (4.2)	4 (5.6)
General Disorders and Administration Site Conditions		
Treatment failure	1 (1.4)	4 (5.6)

In the 3-year extension study, adverse reactions reported in $\geq 5\%$ of patients were (MACI vs microfracture): arthralgia (46.2% vs 50.8%), tendonitis (6.2% vs 1.6%), back pain (4.6% vs 6.3%), osteoarthritis (4.6% vs 7.9%), joint effusion (3.1% vs 7.9%), cartilage injury (6.2% vs 15.9%), procedural pain (3.1% vs 7.9%), ligament sprain (1.5% vs 7.9%), and treatment failure (4.6% vs 7.9%).

Serious adverse reactions reported in patients in either treatment group for integrated data across the 2-year clinical trial and the 3-year extension study are provided in Table 2.

Table 2. Serious Adverse Reactions in Patients in Any Treatment Group Across the 2-Year Clinical Trial and the 3-Year Extension Study

System Organ Class	MACI n = 72 n (%)	Microfracture n = 72 n (%)
Musculoskeletal and Connective Tissue Disorders		
Arthralgia	1 (1.4)	7 (9.7)
Joint Lock	0	3 (4.2)
Meniscus Injury	3 (4.2)	0
Osteoarthritis	3 (4.2)	0
Injury, Poisoning and Procedural Complications		
Cartilage injury	3 (4.2)	8 (11.1)
General Disorders and Administration Site Conditions		
Treatment failure	3 (4.2)	7 (9.7)

6.2 Postmarketing Experience

Graft complication (e.g., abnormalities to the repair graft that become symptomatic; this could include graft overgrowth [tissue hypertrophy], under-fill or damage to the repair tissue that has elicited a painful response, or mechanical symptoms), graft delamination (i.e., a dislodging of the repair graft from the underlying subchondral bone that has become symptomatic; this can be measured as marginal, partial, or a complete delaminated graft), and tendonitis have been reported during use of MACI outside the United States. Because these reactions are reported voluntarily from a population of uncertain size, it is not always possible to reliably estimate their frequency or establish a causal relationship to MACI exposure.

8 USE IN SPECIFIC POPULATIONS

8.1 Pregnancy

Risk Summary

MACI implantation requires invasive surgical procedures; therefore use during pregnancy is not recommended. Limited clinical data on patients exposed to MACI during pregnancy are available. There are insufficient data with MACI use in pregnant women to inform a product-associated risk. Animal reproduction studies have not been conducted with MACI. In the U.S. general population, the estimated background risk of major birth defects and miscarriage in clinically recognized pregnancies is 2-4% and 15-20%, respectively.

8.2 Lactation

Risk Summary

There is no information regarding the presence of MACI in human milk, the effects on the breastfed infant, or the effects on milk production. The developmental and health benefits of breastfeeding should be considered along with the mother's clinical need for MACI and any potential adverse effects on the breastfed infant from MACI or from the underlying maternal condition.

8.4 Pediatric Use

The safety and effectiveness of MACI in pediatric patients have not been established.

8.5 Geriatric Use

The safety and effectiveness of MACI in patients over 65 years of age have not been established. Clinical trials of MACI did not include subjects over the age of 55.

11 DESCRIPTION

MACI, autologous cultured chondrocytes on porcine collagen membrane, is a cellular sheet that consists of autologous chondrocytes seeded on a 3 x 5 cm, resorbable porcine Type I/III collagen membrane, for implantation into cartilage defects of the knee. The active ingredients of MACI are the autologous cultured chondrocytes and porcine Type I/III collagen. The autologous chondrocytes are propagated in cell culture and are seeded on the collagen at a density of 500,000 to 1,000,000 cells per cm². The final MACI implant contains at least 500,000 cells per cm² and does not contain any preservative.

The product manufacture also uses reagents derived from animal materials. The resorbable, Type I/III, collagen membrane, which is a component of MACI, is porcine-derived. Fetal bovine serum is a component in the culture medium used to propagate the autologous chondrocytes; therefore, trace quantities of bovine-derived proteins may be present in MACI. These animal-derived reagents are tested for viruses, retroviruses, bacteria, fungi, yeast, and mycoplasma before use.

MACI may contain residual gentamicin because it is included during manufacture. Gentamicin is not included in the transport medium used to maintain product stability. Studies determined an average of 9.2 µg residual gentamicin per MACI implant.

A final sterility test is initiated prior to shipping, but the result will not be available prior to implantation. Passing results from preliminary in-process microbial tests are required for release of MACI for shipping.

12 CLINICAL PHARMACOLOGY

12.1 Mechanism of Action

No clinical pharmacology studies have been conducted with MACI and a mechanism of action has not been established.

12.3 Pharmacokinetics

Clinical pharmacokinetic studies have not been performed with MACI. Studies in rabbits and horses indicated that the membrane is resorbed over a period of at least 6 months following implantation.

13 NONCLINICAL TOXICOLOGY

13.1 Carcinogenesis, Mutagenesis, Impairment of Fertility

Studies to evaluate the carcinogenicity or impairment of fertility potential of MACI have not been performed. In vitro studies have shown that the expansion process for chondrocytes does not induce changes to the cellular karyotype.

Four studies (*in vitro* and *in vivo*) were conducted to assess the genotoxic potential of the collagen membrane. The results from these studies demonstrated that the collagen membrane was non-mutagenic.

13.2 Animal Toxicology and/or Pharmacology

Implantation of analogous products in critical-size defects in the hind limbs of rabbits and horses did not reveal any serious safety concerns. The products consisted of the same membrane as MACI with rabbit or horse cells, respectively. Non-clinical testing has shown that the collagen membrane is not toxic and is compatible with biological tissue.

14 CLINICAL STUDIES

The effectiveness of MACI implant was evaluated in a 2-year prospective, multicenter, randomized, open-label, parallel-group study, SUMMIT (Superiority of MACI implant versus Microfracture Treatment in patients with symptomatic articular cartilage defects in the knee),¹ which enrolled a total of 144 subjects, ages 18 to 54 years, with at least one symptomatic Outerbridge Grade III or IV focal cartilage defect on the medial femoral condyle, lateral femoral condyle, and/or the trochlea. Failure of a prior cartilage surgery was not required for study entry. The subjects were randomized to receive either a 1-time treatment with MACI or microfracture. The co-primary efficacy endpoint was change from baseline to Week 104 for the subject's Knee injury and Osteoarthritis Outcome Score (KOOS) in two subscales: Pain and Function (Sports and Recreational Activities [SRA])². Safety also was evaluated through Week 104 [*see Adverse Reactions (6.1)*].

Of the 72 subjects randomized to MACI, 70 completed the study and 2 discontinued prematurely (1 due to an adverse event [AE] and 1 wished to withdraw). Of the 72 subjects randomized to microfracture, 67 completed the study and 5 discontinued prematurely (1 due to an AE, 1 wished to withdraw, and 3 due to lack of clinical benefit).

At Week 104, KOOS pain and function (SRA) had improved from baseline in both treatment groups, but the improvement was statistically significantly ($p = 0.001$) greater in the MACI group compared with the microfracture group (Table 3).

Table 3. Change in KOOS Pain and Function (SRA) Scores in the 2-Year Study

	MACI Mean (SD)			Microfracture Mean (SD)		
	N	Pain	Function	N	Pain	Function
Baseline	72	37.0 (13.5)	14.9 (14.7)	71	35.4 (12.1)	12.6 (16.7)
Week 104	72	82.4 (16.2)	60.9 (27.8)	70	70.9 (24.2)	48.7 (30.3)
Change From Baseline to Week 104	72	45.4 (21.1)	46.0 (28.4)	69	35.2 (23.9)	35.8 (31.6)
LS Means (Week 104)		44.1	46.1		32.4	34.6
Difference * [MACI – Microfracture]		11.8	11.4			
p-value **		0.001				

LS = least squares; KOOS = Knee injury and Osteoarthritis Outcome Score; SD = standard deviation; SRA = Sports and Recreational Activities.

* Difference in least squares mean values at Week 104 [MACI – Microfracture].

**p-value for difference in co-primary endpoints assessed jointly at Week 104 based on multivariate analysis of variance.

In a responder analysis, the proportion of subjects with at least a 10-point improvement in both KOOS pain and function (SRA) was greater in the MACI group (63/72=87.5%; 95% CI [77.6%, 94.1%]) compared with the microfracture group (49/72=68.1%; 95% CI [56.0%, 78.6%]).

All subjects from the 2-year study had the option to enroll in a 3 year follow-up study (extension study), in which 128 subjects participated. All 65 subjects (100%, 65/65) in the MACI group and 59 subjects (93.7%, 59/63) in the microfracture group completed the extension study. The mean 2-year KOOS pain and function scores remained stable for the additional 3-year period in both treatment groups (Table 4).

Table 4. KOOS Pain and Function (SRA) Scores in the 3-Year Extension Study

Visit	MACI			Microfracture		
	N	Pain mean (SD)	Function mean (SD)	N	Pain mean (SD)	Function mean (SD)
Baseline	65/65	37.1 (13.1)	15.4 (14.8)	63/63	35.2 (12.3)	11.9 (16.2)
2 Years	63/63	82.2 (15.8)	60.5 (26.5)	60/60	71.8 (23.9)	48.9 (30.6)
5 Years	65/64	82.2 (20.1)	61.9 (30.9)	59/59	74.8 (21.7)	50.3 (32.3)

15 REFERENCES

1. Saris D, Price A, Widuchowski W, Bertrand-Marchand M, Caron J, Drogset JO, et al. Matrix-applied characterized autologous cultured chondrocytes versus microfracture: two-year follow-up of a prospective randomized trial. Am J Sports Med. 2014 Jun;42(6):1384-94.
2. Roos EM, Lohmander LS. The Knee injury and Osteoarthritis Outcome Score (KOOS): from joint injury to osteoarthritis. Health Qual Life Outcomes. 2003;1:64.

16 HOW SUPPLIED/STORAGE AND HANDLING

How Supplied

- A single patient order may contain 1 or 2 implants, each in its own dish and shipper, depending on lesion size and number of lesions.
- MACI, NDC69866-1030-1, contains 1 implant supplied ready for use as a single cellular sheet approximately 3 x 5 cm, in a sterile, sealed, clear polystyrene dish. Each dish contains one 3 x 5 cm implant with a 0.5-cm² section removed from the lower left hand corner, held in place by a polycarbonate 5-pronged ring closed with a polycarbonate cover for shipment.
- MACI, NDC69866-1030-2, contains 2 implants supplied ready for use as cellular sheets approximately 3 x 5 cm, in a sterile, sealed, clear polystyrene dish. Each dish contains one 3 x 5 cm implant with a 0.5 cm² section removed from the lower left hand corner, held in place by a polycarbonate 5 pronged ring closed with a polycarbonate cover for shipment.
- Each dish is individually sealed in a clear plastic bag. The plastic bag(s) are placed into one 95kPa pouch (outer bag) with absorbent material. This pouch is enclosed in an outer carton insulated with ambient temperature gel packs.
- MACI is shipped cell-side up.

Storage and Handling

- Store MACI at room temperature in its original packaging (outer carton) until ready to use.
- DO NOT REFRIGERATE or FREEZE, or sterilize MACI.
- Do not use if the dish is damaged or has been compromised.
- Use MACI prior to 11:59 PM ET on the date of expiration printed on the package.
- Dispose of unused MACI or waste material as surgical biohazardous waste in accordance with local requirements.

17 PATIENT COUNSELING INFORMATION

- Advise the patient that:

- A cartilage biopsy is needed to manufacture MACI. The biopsy is typically performed as an arthroscopic procedure at the time of diagnosis confirmation.
- The length of time between the biopsy and the implantation of MACI may vary depending on many factors, including the quality and number of cells obtained from the biopsy. On average this will take 6 weeks; however, cells can be held in storage until a convenient date for surgery is agreed upon between the patient and the surgeon.
- Even if the surgeon has taken a biopsy needed to produce MACI, it may be possible that the patient cannot be treated with MACI, (e.g., in case the biopsy is of insufficient quality to produce MACI, if the cells cannot be grown in the laboratory, or if the expanded cells do not meet all the quality requirements).
- Advise the patient on the risk of graft complications, subsequent surgical procedures, and treatment failure. [*See Adverse Reaction (6)*]
- Advise the patient on general complications related to knee surgery, which may include deep vein thrombosis and pulmonary embolism.
- Advise the patient to closely follow the physician-prescribed rehabilitation program, which will include limitations and allowances for beginning specific physical activities. [*See Dosage and Administration (2.3)*]

Manufactured by: Vericel Corporation, 64 Sidney Street, Cambridge, MA 02139

MACI[®] is a registered trademark of Vericel Corporation.

© 2016 Vericel Corporation.

65617.A